

# HEAVY DUTY STRAIGHT TRACK 400 SERIES

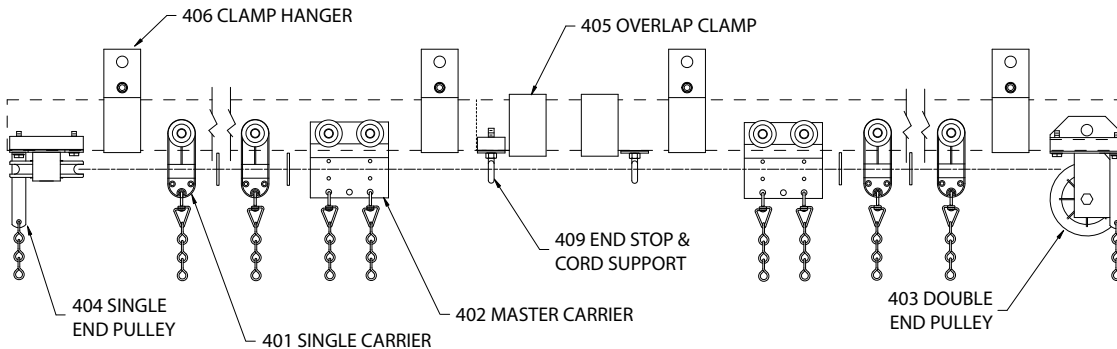

## COMPLETE TRACK MODEL NUMBERS

401A	401S	401W
416A	416S	416P 416W
418A	418S	418P 418W
428A	428S	428W

## BLACK COMPLETE TRACK MODEL NUMBERS

401SB	401WB
416SB	416PB 416WB
418SB	418PB 418WB
428SB	428WB

The 400 Series is a straight track offered in many models for a variety of project requirements. This heavy-duty track is available in galvanized steel, black powder-coated steel and mill finish aluminum. In addition to the traditional zinc plated finish, all hardware items are available in black finish to meet the demands of the theatrical industry.

Model 401S is recommended for moderately heavy curtains up to 60 feet in width. It utilizes ball bearing carriers with polyethylene wheels and 4" end pulleys. Model 428S is an economical upgrade to urethane wheels and 6" pulleys when a quiet track is desired for larger curtains.

Models 416S and 418S feature improved carriers with a custom designed, sealed ball bearing in each wheel. The 416 carrier is equipped with nylon-tired wheels for minimized friction when moving heavy loads. The 418 carrier has been redesigned with a urethane tire that combines durability with quiet operation. Each is complemented by 6" end pulleys for rigging curtains of virtually any length. The Premier versions, Models 416P and 418P, are the best in heavy-duty straight tracks. They incorporate 1/2" operating line, rear fold guides and 8" end pulleys for maximum ease of operation of very heavy stage curtains.

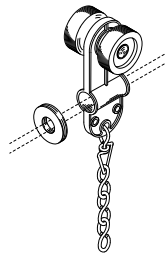

### SINGLE CARRIER

2 polyethylene wheels riveted to black Super Tough nylon body with shielded ball bearing. Heavy-duty hook, swivel, and trim chain for curtain attachment. Supplied with 1 No. 431 rubber bumper.  
**No. 401** - Zinc plated.  
**No. 401B** - Black finish.

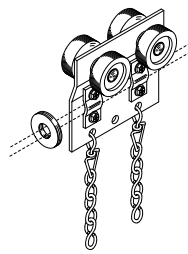

### MASTER CARRIER

4 polyethylene wheels riveted to steel body with 2 shielded ball bearings. 2 clamps provided for anchoring operating line or cable. Supplied with 1 No. 431 rubber bumper. 1 pair required for overlapping tracks.  
**No. 402** - Zinc plated.  
**No. 402B** - Black finish.

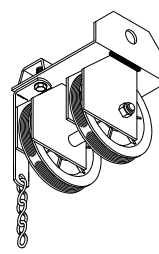

### DOUBLE END PULLEY

4" diameter MD Nylon sheaves with shielded ball bearings. Steel housing clamps to underside of track. Chain bracket for securing offstage curtain edge. 3/8" groove.  
**No. 403** - Zinc plated.  
**No. 403B** - Black finish.

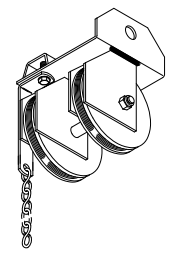

### No. 403M BLACK DOUBLE END PULLEY

Heavy-duty 4" diameter MD Nylon sheaves with sealed precision ball bearings. Steel housing clamps to underside of track. Chain bracket for securing offstage curtain edge. 3/16" groove for use with motorized tracks.

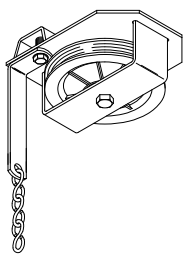

### SINGLE END PULLEY

4" diameter MD Nylon sheave with shielded ball bearing. Steel housing clamps to underside of track. Chain bracket for securing offstage curtain edge. 3/8" groove.  
**No. 404** - Zinc plated.  
**No. 404B** - Black finish.

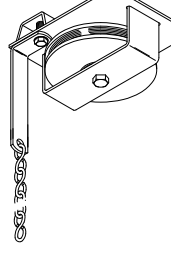

### No. 404M BLACK SINGLE END PULLEY

Heavy-duty 4" diameter MD Nylon sheave with sealed precision ball bearings. Steel housing clamps to underside of track. Chain bracket for securing offstage curtain edge. 3/16" groove for use with motorized tracks.

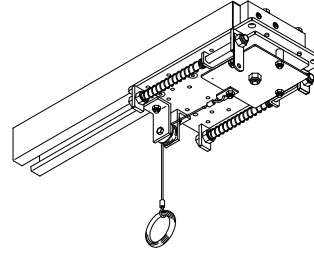

### No. 404T BLACK TENSIONING END PULLEY

4" diameter MD Nylon sheave with sealed precision ball bearings grooved for 3/16" cable. Heavy-duty steel housing clamps to underside of track and provides constant cable tension on large motorized tracks.

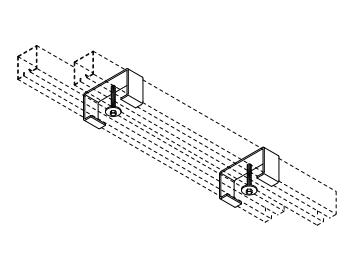

### OVERLAP CLAMP

Formed steel clamps to align track at overlap. 1 set pictured.  
**No. 405** - Zinc plated.  
**No. 405B** - Black finish.

# HEAVY DUTY STRAIGHT TRACK 400 SERIES

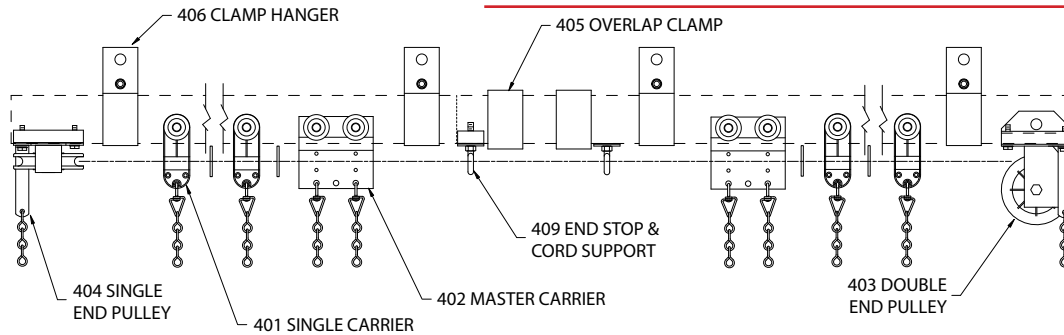

COMPLETE TRACK MODEL NUMBERS		
401A	401S	401W
416A	416S	416P 416W
418A	418S	418P 418W
428A	428S	428W
BLACK COMPLETE TRACK MODEL NUMBERS		
401SB		401WB
416SB	416PB	416WB
418SB	418PB	418WB
428SB		428WB

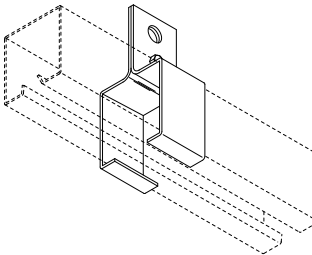
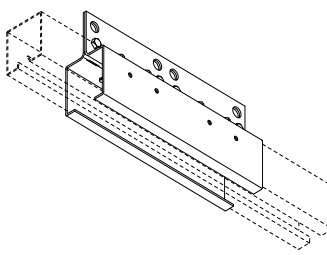
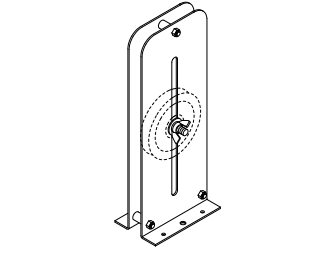
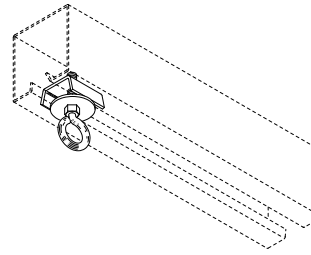
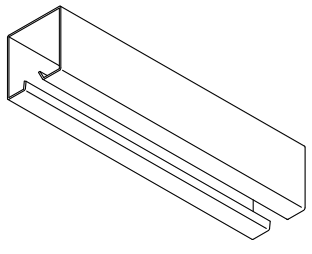
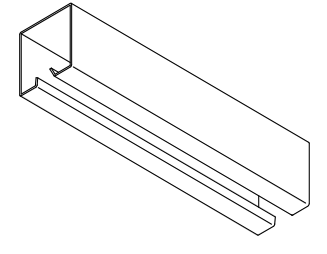
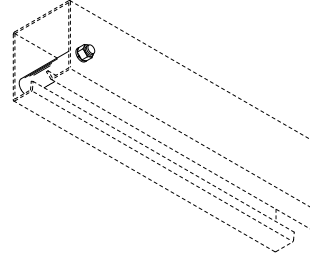
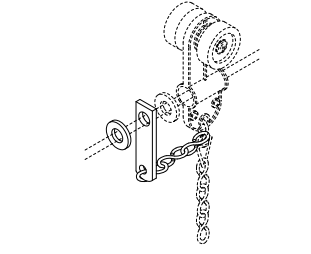
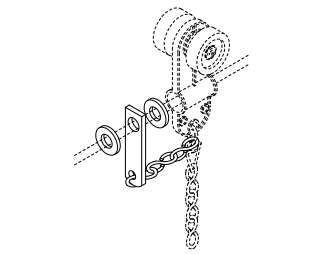
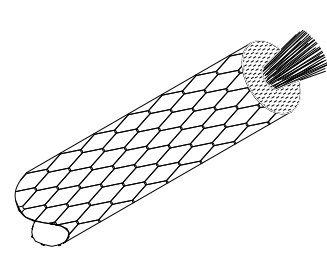
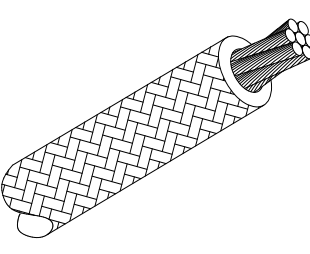
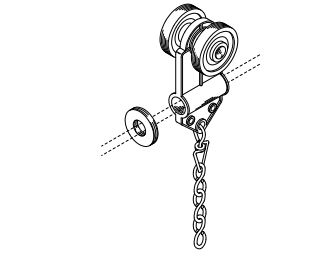
 <p><b>CLAMP HANGER</b> Formed steel brackets clamp to track. Adjusts to any position. Suspend track with welded chain or wire rope. 1 pair pictured. <b>NO. 406</b> - Zinc plated. <b>NO. 406B</b> - Black finish.</p>	 <p><b>SPLICE</b> Formed steel brackets align and lock track sections together. 1 pair pictured. <b>No. 407</b> - Zinc plated. <b>No. 407B</b> - Black finish.</p>	 <p><b>No. 408 BLACK ADJUSTABLE FLOOR BLOCK</b> 4" diameter MD Nylon sheave with shielded ball bearing in steel housing. 9" vertical adjustment.</p>	 <p><b>END STOP &amp; CORD SUPPORT</b> Steel clamp with eye to support operating line and prevent carriers from traveling beyond desired location. 1 pair required for overlapping tracks. <b>DO NOT USE WITH PIVOT DEVICES.</b> <b>No. 409</b> - Zinc plated. <b>No. 409B</b> - Black finish.</p>
 <p><b>No. 410A TRACK</b> Mill finish 6063-T5 extruded aluminum 2-5/8" wide x 2-3/4" high, .080" thick. 20' and 24' stock lengths.</p>	 <p><b>No. 410S TRACK</b> 14 gauge galvanized steel, roll-formed to 2-5/8" wide x 2-3/4" high. <b>No. 410S-</b> 16', 20', 24', and 26' stock lengths. <b>No. 410S-B- Semi-gloss black powder coat finish.</b> 16", 20", and 24" stock lengths.</p>	 <p><b>END STOP</b> Bolt with steel spacer to prevent carriers from traveling beyond desired location. For use with walk-along tracks and tracks with pivot devices. <b>No. 411</b> - Zinc plated. <b>No. 411B</b> - Black finish.</p>	 <p><b>REAR FOLD GUIDE</b> Allows curtain to fold at offstage edges. Supplied with 1 No. 431 rubber bumper. <b>No. 412</b> - for use with 3/8" operating line. <b>No. 412B</b> - same as 412 in Black</p>
 <p><b>REAR FOLD GUIDE</b> Allows curtain to fold at offstage edges. Supplied with 2 rubber bumpers. <b>No. 412A</b> - for use with 1/2" operating line. Black finish. <b>No. 413</b> - for use with 3/16" operating cable. <b>No. 413B</b> - same as 413 in Black</p>	 <p><b>No. 414 OPERATING LINE</b> 3/8" diameter black polyester braided over Dyneema core for manual operation.</p>	 <p><b>No. 415 OPERATING CABLE</b> 3/16" diameter black polyester jacket braided over 3/32" specialty cord wire rope. For use with motorized tracks.</p>	 <p><b>No. 416 BLACK SINGLE CARRIER</b> 2 nylon-tired sealed ball bearing wheels riveted to black Super Tough nylon body with heavy-duty hook, swivel and 6" trim chain for curtain attachment. Supplied with 1 No. 431 rubber bumper.</p>

# HEAVY DUTY STRAIGHT TRACK 400 SERIES

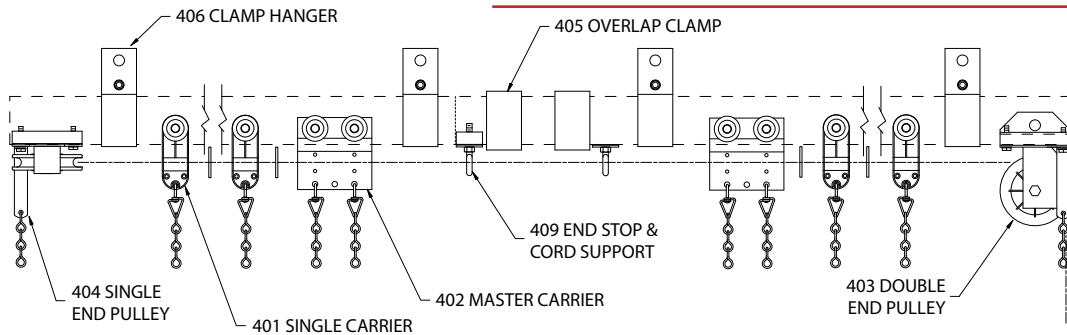

## COMPLETE TRACK MODEL NUMBERS

401A	401S	401W
416A	416S	416P 416W
418A	418S	418P 418W
428A	428S	428W

## BLACK COMPLETE TRACK MODEL NUMBERS

401SB	401WB
416SB	416PB 416WB
418SB	418PB 418WB
428SB	428WB

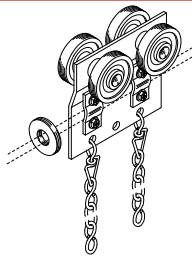

### No. 417 BLACK MASTER CARRIER

4 nylon-tired sealed ball bearing wheels riveted to steel body. 2 clamps provided for anchoring operating line or cable. Supplied with 1 No. 431 rubber bumper. 1 pair required for overlapping tracks.

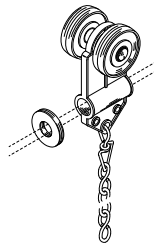

### No. 418 BLACK SINGLE CARRIER

2 urethane-tired sealed ball bearing wheels riveted to black Super Tough nylon body with heavy-duty hook, swivel and 6" trim chain for curtain attachment. Supplied with 1 No. 431 rubber bumper.

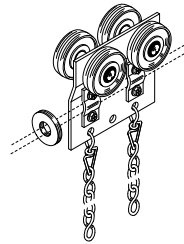

### No. 419 BLACK MASTER CARRIER

4 urethane-tired sealed ball bearing wheels riveted to steel body. 2 clamps provided for anchoring operating line or cable. Supplied with 1 No. 431 rubber bumper. 1 pair required for overlapping tracks.

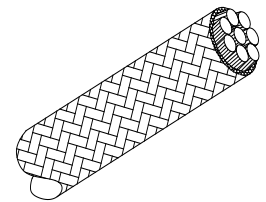

### No. 420 OPERATING LINE

1/2" diameter black spun polyester braided over polyester core for manual operation.

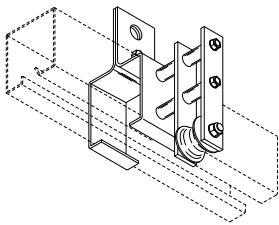

### CLAMP HANGER WITH IDLER

No. 406 clamp hanger with MD Nylon ball bearing roller for supporting operating line or cable.  
**NO. 421** - Zinc plated.  
**NO. 421B** - Black finish.

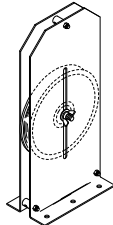

### No. 422, BLACK 8" ADJUSTABLE FLOOR BLOCK

8" diameter MD Nylon sheave with sealed precision ball bearings in heavy-duty steel housing with 9" vertical adjustment. Grooved to accept up to 1/2" operating line.

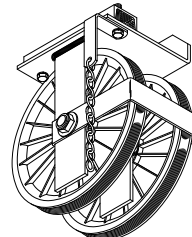

### BLACK 8" DOUBLE END PULLEY

8" diameter MD Nylon sheaves with sealed precision ball bearings. Heavy-duty steel housing clamps to underside of track. Chain bracket for securing offstage curtain edge.  
**No. 423** - Grooved for up to 1/2" operating line.  
**No. 423M** - Grooved for 3/16" operating cable.

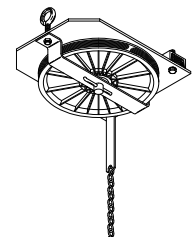

### BLACK 8" SINGLE END PULLEY

8" diameter MD Nylon sheave with sealed precision ball bearings. Heavy-duty steel housing clamps to underside of track. Chain bracket for securing offstage curtain edge.  
**No. 424** - Grooved for up to 1/2" operating line.  
**No. 424M** - Grooved for 3/16" operating cable.

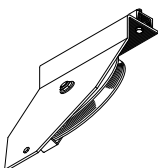

### BLACK 8" SLANTED SINGLE END PULLEY

8" diameter MD Nylon sheave with sealed precision ball bearings. Heavy-duty steel housing clamps to underside of track. Chain bracket for securing offstage curtain edge. Allows a narrower profile when installed.  
**No. 424A** - Grooved for up to 1/2" operating line.  
**No. 424AM** - Grooved for 3/16" operating cable.

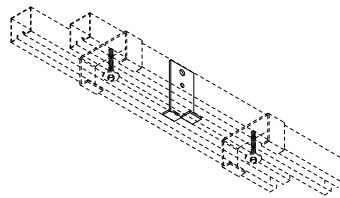

### CENTER PIPE SUPPORT

Formed steel bracket used to support tracks at overlap.  
**No. 426** - Zinc plated.  
**No. 426B** - Black finish.

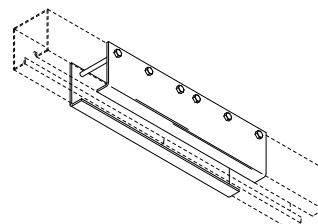

### CEILING SPLICE

To align and lock track sections together on ceiling mounted tracks. 1 pair pictured.  
**Note: Cannot be used with No. 437 Locking Master or No. 40 Pivot Device due to interference with the wheels.**  
**No. 427** - Zinc plated.  
**No. 427B** - Black finish.

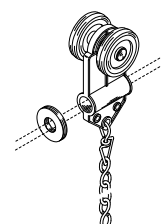

### No. 428 BLACK SINGLE CARRIER

2 urethane-tired wheels riveted to black Super Tough nylon body with shielded ball bearing. Heavy-duty hook, swivel and 6" trim chain for curtain attachment. Supplied with 1 No. 431 rubber bumper.

# HEAVY DUTY STRAIGHT TRACK 400 SERIES

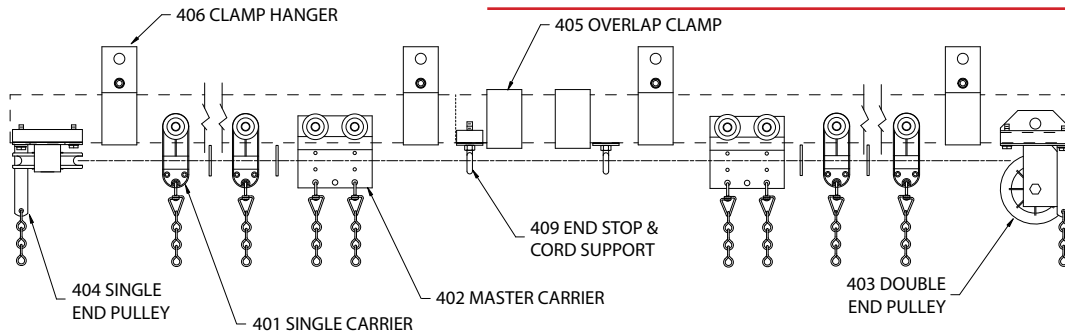

## COMPLETE TRACK MODEL NUMBERS

401A	401S	401W
416A	416S	416P 416W
418A	418S	418P 418W
428A	428S	428W

## BLACK COMPLETE TRACK MODEL NUMBERS

401SB	401WB
416SB	416PB 416WB
418SB	418PB 418WB
428SB	428WB

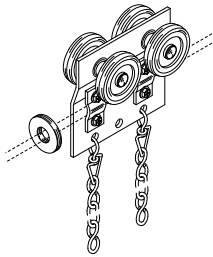

### NO. 429 BLACK MASTER CARRIER

4 urethane-tired wheels riveted to steel body with 2 shielded ball bearings. 2 clamps provided for anchoring operating line or cable. Supplied with 1 No. 431 rubber bumper. 1 pair required for overlapping tracks.

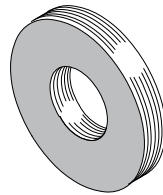

### ROUND RUBBER BUMPER

1/8" neoprene bumper placed between carriers on operating line to reduce noise.  
**No. 430** - for use with 3/16" operating cable.  
**No. 431** - for use with 3/8" operating line.  
**No. 431A** - for use with 1/2" operating line.

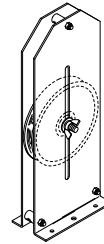

### NO. 432, BLACK 6" ADJUSTABLE FLOOR BLOCK

6" diameter MD Nylon sheave with sealed precision ball bearings in heavy-duty steel housing with 9" vertical adjustment. Grooved to accept up to 1/2" operating line.

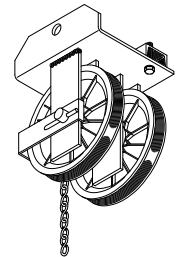

### 6" BLACK DOUBLE END PULLEY

6" diameter MD Nylon sheaves with precision sealed ball bearings. Heavy-duty steel housing clamps to underside of track. Chain bracket for securing offstage curtain edge.  
**No. 433** - Grooved for up to 1/2" operating line.  
**No. 433M** - Grooved for 3/16" operating cable.

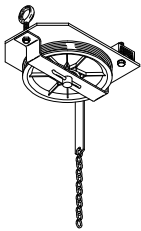

### 6" BLACK SINGLE END PULLEY

6" diameter MD Nylon sheave with sealed precision ball bearings. Heavy-duty steel housing clamps to underside of track. Chain bracket for securing offstage curtain edge.  
**No. 434** - Grooved for up to 1/2" operating line.  
**No. 434M** - Grooved for 3/16" operating cable.

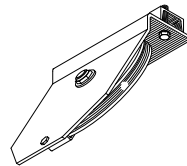

### BLACK 6" SLANTED SINGLE END PULLEY

6" diameter MD Nylon sheave with sealed precision ball bearings. Heavy-duty steel housing clamps to underside of track. Chain bracket for securing offstage curtain edge. Allows a narrower profile when installed.  
**No. 434A** - Grooved for up to 1/2" operating line.  
**No. 434AM** - Grooved for 3/16" operating cable.

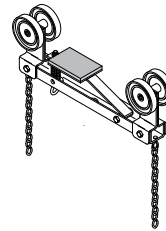

### NO. 437 BLACK LOCKING MASTER CARRIER

Heavy steel construction with nylon wheels and brake to keep master carrier in desired location. Equipped with swivels and trim chains for curtain attachment. Note: All carriers used with this device must have a trim chain of 6" total length.

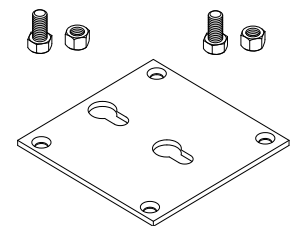

### BLACK DETACHABLE FLOOR BLOCK KIT

7 gauge steel plate with hardware for use with floor block for quick release.  
**No. 408DK** - use with No. 408 4" Floor Block.  
**No. 422DK** - use with No. 422 8" Floor Block.  
**No. 432DK** - use with No. 432 6" Floor Block.

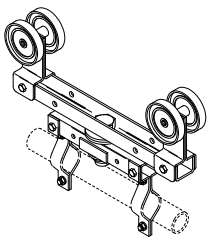

### 40 PIVOT DEVICE

Heavy steel construction with nylon wheels. Supplied with brackets for 1-3/8" O.D. pipe or tubing (6' max. recommended length). Allows masking draperies to be rotated to any angle.

Working Load Limit: 60 pounds.

**No. 40** - Zinc plated.  
**No. 40B** - Black finish.

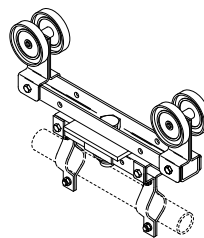

### INDEXING PIVOT DEVICE

Pivot device with special plate to index rotation at 22-1/2 degree increments. Supplied with brackets for 1-3/8" O.D. pipe or tubing (6' max. recommended length).

Working Load Limit: 60 pounds.

**No. 40X** - Zinc plated.  
**No. 40XB** - Black finish.

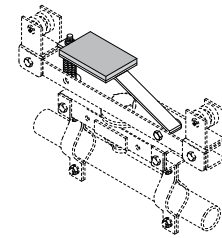

### BRAKE KIT

Spring equipped arm with neoprene pad. Add to pivot device to prevent undesired movement along track.

**No. 40BK** - Zinc plated.  
**No. 40BKB** - Black finish.

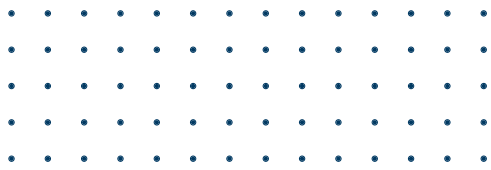

# WALK-ALONG TRACK COMPONENT GUIDE

## 400 SERIES

### WALK-ALONG TRACK COMPONENT GUIDE

PART No.	DESCRIPTION	401W	416W	418W	428W
401	Single Carrier	•			
402	Master Carrier	•			
406	Clamp Hanger	•	•	•	•
407*	Splice	•	•	•	•
409	End Stop & Cord Support	•	•	•	•
410S*	Track	•	•	•	•
416	Black Nylon B.B. Single Carrier		•		
417	Black Nylon B.B. Master Carrier		•		
418	Black Urethane B.B. Single Carrier			•	
419	Black Urethane B.B. Master Carrier			•	
428	Black Urethane Single Carrier				•
429	Black Urethane Master Carrier				•

\* Track lengths and splices supplied as required from stock sizes.

### BLACK WALK-ALONG TRACK COMPONENT GUIDE

PART No.	DESCRIPTION	401WB	416WB	418WB	428WB
401B	Black Single Carrier	•			
402B	Black Master Carrier	•			
406B	Black Clamp Hanger	•	•	•	•
407B*	Black Splice	•	•	•	•
409B	Black End Stop & Cord Support	•	•	•	•
410S-B*	Black Track	•	•	•	•
416	Black Nylon B.B. Single Carrier		•		
417	Black Nylon B.B. Master Carrier		•		
418	Black Urethane B.B. Single Carrier			•	
419	Black Urethane B.B. Master Carrier			•	
428	Black Urethane Single Carrier				•
429	Black Urethane Master Carrier				•

\* Track lengths and splices supplied as required from stock sizes.



# COMPLETE TRACK COMPONENT GUIDE 400 SERIES

---

## COMPLETE TRACK COMPONENT GUIDE

PART No.	DESCRIPTION	401S	416S	416P	418S	418P	428S
401	Single Carrier	•					
402	Master Carrier	•					
403	4" Double End Pulley	•					
404	4" Single End Pulley	•					
405	Overlap Clamp	•	•	•	•	•	•
406	Clamp Hanger	•	•	•	•	•	•
407*	Splice	•	•	•	•	•	•
408	Black 4" Adjustable Floor Block	•					
409	End Stop & Cord Support	•	•	•	•	•	•
410S*	Track	•	•	•	•	•	•
412A	Black 1/2" Rear Fold Guide			•		•	
414	3/8" Operating Line	•	•		•		•
416	Black Nylon B.B. Single Carrier		•	•			
417	Black Nylon B.B. Master Carrier		•	•			
418	Black Urethane B.B. Single Carrier				•	•	
419	Black Urethane B.B. Master Carrier				•	•	
420	1/2" Operating Line			•		•	
421	Clamp Hanger with Idler			•		•	
422	Black 8" Adjustable Floor Block			•		•	
423	Black 8" Double End Pulley			•		•	
424	Black 8" Single End Pulley			•		•	
426	Center Pipe Support			•		•	
428	Black Urethane Single Carrier						•
429	Black Urethane Master Carrier						•
432	Black 6" Adjustable Floor Block		•		•		•
433	Black 6" Double End Pulley		•		•		•
434	Black 6" Single End Pulley		•		•		•

\* Track lengths and splices supplied as required from stock sizes.

**For COMPLETE tracks supplied with aluminum, substitute 410A for 410S.**

---



# BLACK COMPLETE TRACK COMPONENT GUIDE 400 SERIES

---

## BLACK COMPLETE TRACK COMPONENT GUIDE

Note: Aluminum track is not offered in black.

PART No.	DESCRIPTION	401SB	416SB	416PB	418SB	418PB	428SB
401B	Black Single Carrier	•					
402B	Black Master Carrier	•					
403B	Black 4" Double End Pulley	•					
404B	Black 4" Single End Pulley	•					
405B	Black Overlap Clamp	•	•	•	•	•	•
406B	Black Clamp Hanger	•	•	•	•	•	•
407B*	Black Splice	•	•	•	•	•	•
408	Black 4" Adjustable Floor Block	•					
409B	Black End Stop & Cord Support	•	•	•	•	•	•
410S-B*	Black Track	•	•	•	•	•	•
412A	Black 1/2" Rear Fold Guide			•		•	
414	3/8" Operating Line	•	•		•		•
416	Black Nylon B.B. Single Carrier		•	•			
417	Black Nylon B.B. Master Carrier		•	•			
418	Black Urethane B.B. Single Carrier				•	•	
419	Black Urethane B.B. Master Carrier				•	•	
420	1/2" Operating Line			•		•	
421B	Black Clamp Hanger with Idler			•		•	
422	Black 8" Adjustable Floor Block			•		•	
423	Black 8" Double End Pulley			•		•	
424	Black 8" Single End Pulley			•		•	
426B	Black Center Pipe Support			•		•	
428	Black Urethane Single Carrier						•
429	Black Urethane Master Carrier						•
432	Black 6" Adjustable Floor Block		•		•		•
433	Black 6" Double End Pulley		•		•		•
434	Black 6" Single End Pulley		•		•		•

\*Track lengths and splices supplied as required from stock sizes.

---



# HEAVY DUTY STRAIGHT TRACK 400 SERIES

---

## GENERAL SPECIFICATIONS: HEAVY-DUTY STRAIGHT TRACK

Provide **Model 401S** as manufactured by H & H Specialties Inc., South El Monte, CA.

Track shall be 14 gauge galvanized steel, roll-formed to 2-5/8" wide X 2-3/4" high channel with continuous slot in bottom. Provide unspliced in lengths up to 26'.

Suspend track with two-piece clamp hanger formed from 11 gauge steel. Provide 2' overlap at center, rigidly separated by two overlap clamps. Install end stop with cord support at each track end. Where lengths exceed 26', connect tracks with 12" long, two-piece splicing clamp of 12 gauge steel.

Provide single carriers, spaced on 12" centers, constructed of two polyethylene wheels fastened parallel to carrier body. Supply with heavy-duty hook, swivel eye and 3" trim chain for attachment of curtain. Black Super Tough nylon shall be molded around shielded and greased ball bearing to form carrier body. Install round neoprene bumper between each carrier on operating line to reduce noise.

Master carriers shall be 4-wheel assemblies with bodies formed from 11 gauge steel with press-fit ball bearings. Connect to operating line with two formed steel cord clamps attached to each body. Supply each master carrier with two heavy-duty hooks, swivel eyes and 3" trim chains for attachment of leading edge of curtain.

Single and double end pulleys shall clamp securely to the underside of the track channel and shall contain 4" diameter sheaves enclosed in steel housings to prevent operating line from escaping the grooves. Sheaves shall be MD Nylon molded around shielded and greased ball bearings and grooved to accommodate up to 3/8" operating line.

Provide floor block in 12 gauge steel housing containing 4" MD Nylon shielded ball bearing sheave. Sheave axle shall lock at any point within 9" vertical slots to allow tension adjustment of operating line.

Black operating line shall be 3/8" diameter, stretch-resistant rope with spun polyester outer jacket braided over Dyneema core.

All steel components shall be zinc plated to resist corrosion.

---

Provide **Model 416S** as manufactured by H & H Specialties Inc., South El Monte, CA.

Track shall be 14 gauge galvanized steel, roll-formed to 2-5/8" wide X 2-3/4" high channel with continuous slot in bottom. Provide unspliced in lengths up to 26'.

Suspend track with two-piece clamp hanger formed from 11 gauge steel. Provide 2' overlap at center, rigidly separated by two overlap clamps. Install end stop with cord support at each track end. Where lengths exceed 26', connect tracks with 12" long, two-piece splicing clamp of 12 gauge steel.

Provide single carriers, spaced on 12" centers, constructed of two nylon-tired sealed ball bearing wheels fastened parallel to black Super Tough nylon carrier body. Supply with heavy-duty hook, swivel eye and 6" trim chain for attachment of curtain. Install round neoprene bumper between each carrier on operating line to reduce noise.

Master carriers shall be 4-wheel nylon-tired sealed ball bearing assemblies with bodies formed from 11 gauge steel. Connect to operating line with two formed steel cord clamps attached to each body. Supply each master carrier with two heavy-duty hooks, swivel eyes and 6" trim chains for attachment of leading edge of curtain.

Single and double end pulleys shall clamp securely to the underside of the track channel and shall be equipped with 6" diameter MD Nylon sheaves grooved for up to 1/2" operating line. Install two 5/8" sealed precision ball bearings in each sheave. Lock shaft to side plate on head end with 3/16" keeper pin to prevent rotation and install fine-threaded nylon insert lock nut.

Provide floor block in 12 gauge steel housing containing 6" Nylon sheave with two 3/8" sealed precision ball bearings. Sheave axle shall lock at any point within 9" vertical slots to allow tension adjustment of operating line.

Black operating line shall be 3/8" diameter, stretch-resistant rope with spun polyester outer jacket braided over Dyneema core.

All steel components shall be zinc plated to resist corrosion.

---



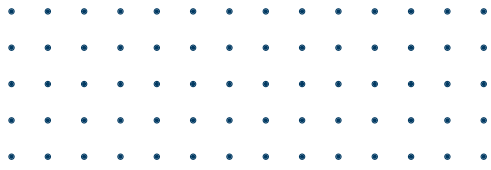

# HEAVY DUTY STRAIGHT TRACK 400 SERIES

---

## GENERAL SPECIFICATIONS: (Continued)

Provide Model **418P** as manufactured by H & H Specialties Inc., South El Monte, CA.

Track shall be 14 gauge galvanized steel, roll-formed to 2-5/8" wide X 2-3/4" high channel with continuous slot in bottom. Provide unspliced in lengths up to 26'.

Suspend track with two-piece clamp hanger formed from 11 gauge steel. Provide 2' overlap at center, rigidly separated by two overlap clamps. Install end stop with cord support at each track end. Where lengths exceed 26', connect tracks with 12" long, two-piece splicing clamp of 12 gauge steel.

Provide single carriers, spaced on 12" centers, constructed of two urethane-tired sealed ball bearing wheels fastened parallel to black Super Tough nylon carrier body. Supply with heavy-duty hook, swivel eye and 6" trim chain for attachment of curtain. Install rear fold guide and two round neoprene bumpers between each carrier on operating line to fold curtain at offstage edges and minimize noise.

Master carriers shall be 4-wheel urethane-tired sealed ball bearing assemblies with bodies formed from 11 gauge steel. Connect to operating line with two formed steel cord clamps attached to each body. Supply each master carrier with two heavy-duty hooks, swivel eyes and 6" trim chains for attachment of leading edge of curtain.

Single and double end pulleys shall clamp securely to the underside of the track channel and shall be equipped with 8" diameter MD Nylon sheaves grooved for 1/2" operating line. Install two 5/8" sealed precision ball bearings in each sheave. Lock shaft to side plate on head end with 3/16" keeper pin to prevent rotation and install fine-threaded nylon insert lock nut.

Provide floor block in 12 gauge steel housing containing 8" MD Nylon sheave with two 3/8" sealed precision ball bearings. Sheave axle shall lock at any point within 9" vertical slots to allow tension adjustment of operating line.

Black operating line shall be 1/2" diameter, stretch-resistant rope with spun polyester outer jacket braided over Dyneema core.

All steel components shall be zinc plated to resist corrosion.

---

# TRACK 401S SERIES

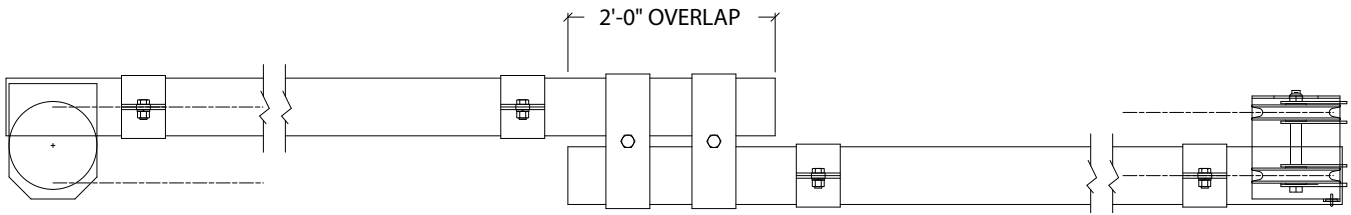

**PLAN - MODEL 401S COMPLETE TRACK**

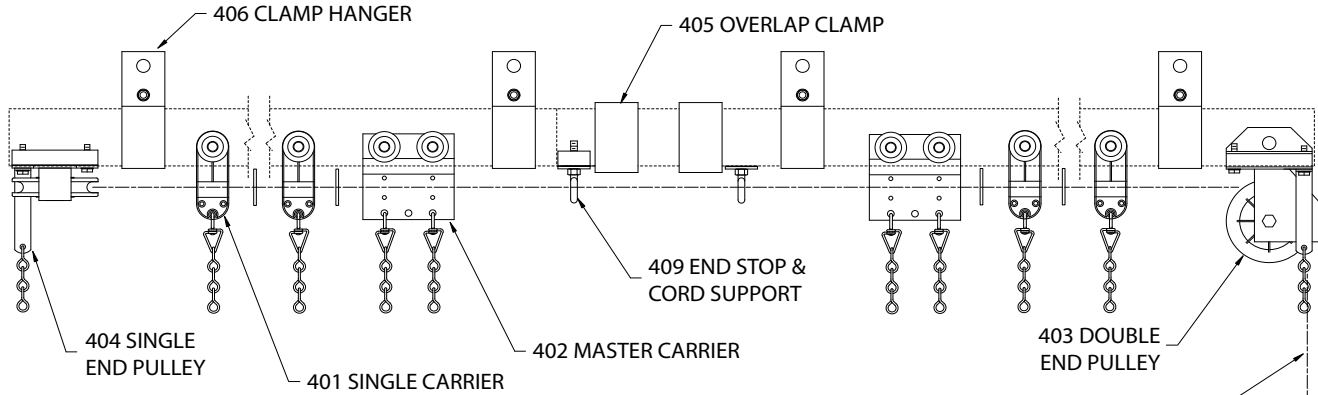

**ELEVATION - MODEL 401S COMPLETE TRACK**

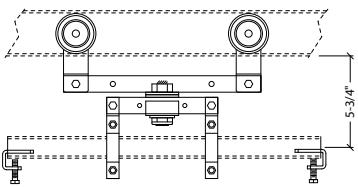

**40 PIVOT DEVICE**

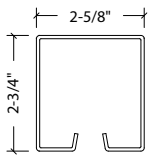

**410 TRACK**

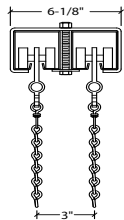

**TRACKS AT CENTER OVERLAP**

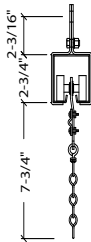

**401 SINGLE CARRIER AND 402 MASTER CARRIER**

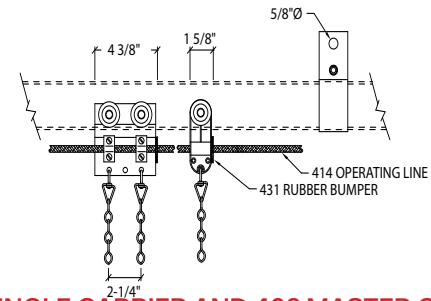

414 OPERATING LINE

408 BLACK ADJUSTABLE FLOOR BLOCK

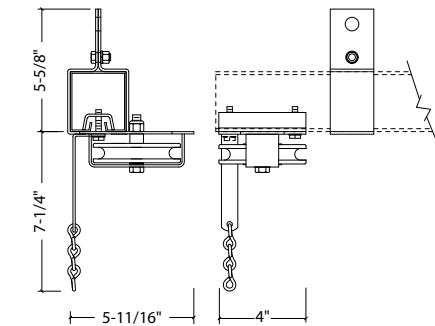

**404 SINGLE END PULLEY**

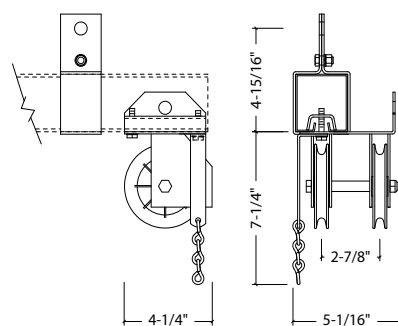

**403 DOUBLE END PULLEY**

# TRACK 416S SERIES

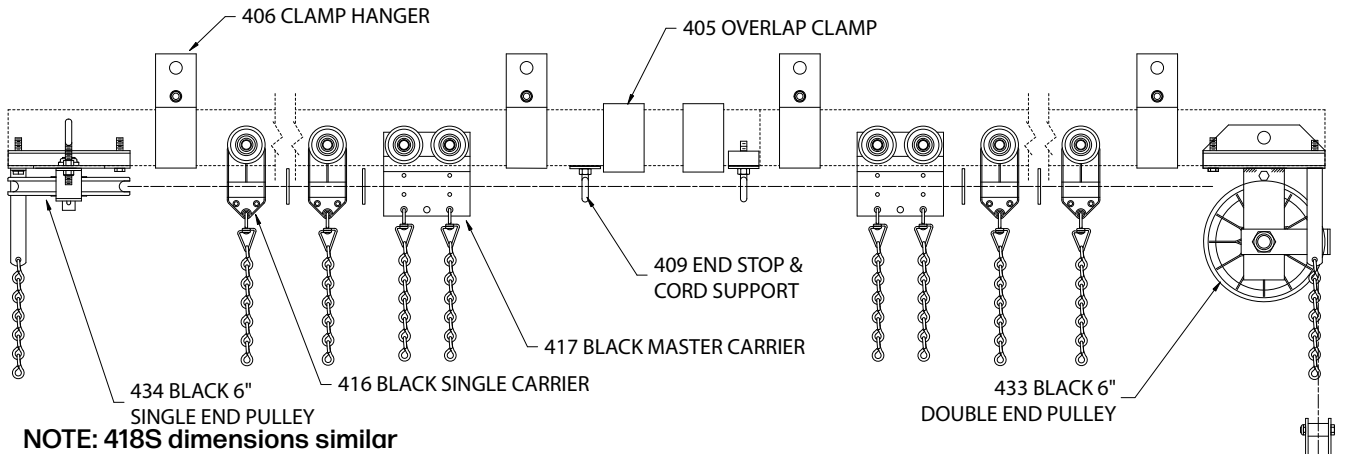
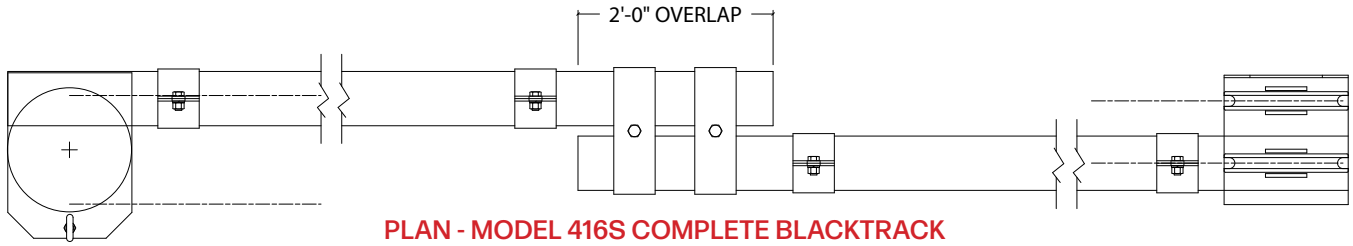

**NOTE: 418S dimensions similar**

## ELEVATION - MODEL 416S COMPLETE BLACK TRACK

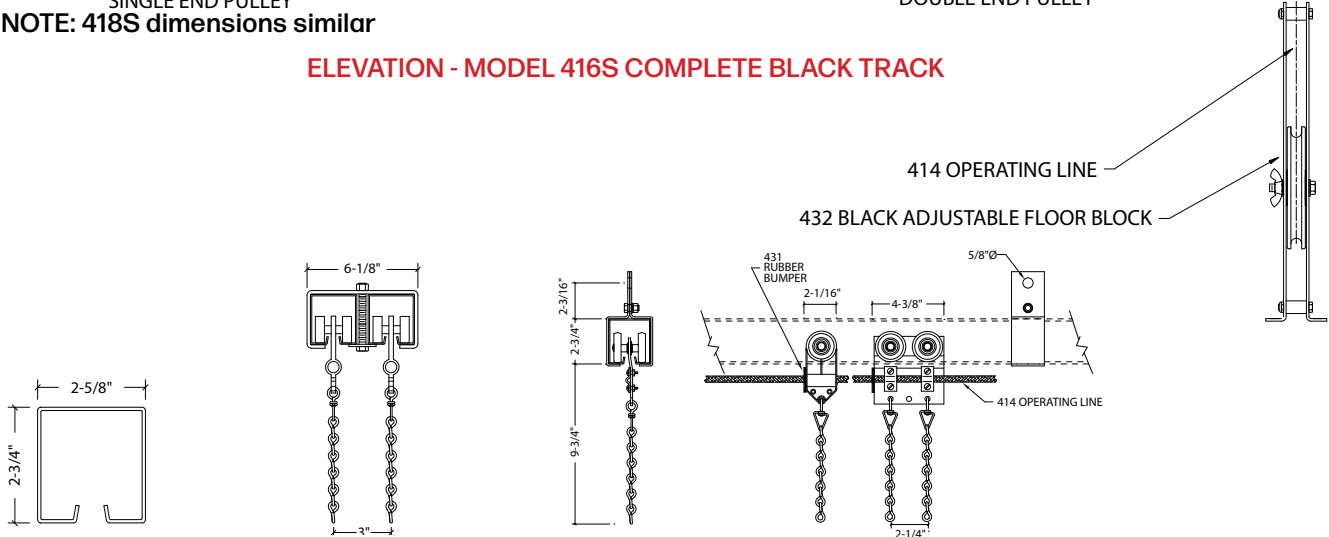

**410 TRACK**

**TRACKS AT CENTER OVERLAP**

**416 BLACK SINGLE CARRIER AND 417 BLACK MASTER CARRIER**

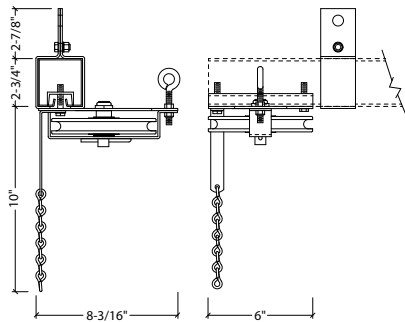

**434 6" BLACK SINGLE END PULLEY**

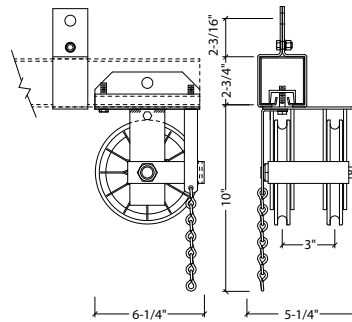

**433 6" BLACK DOUBLE END PULLEY**

# TRACK 418P SERIES

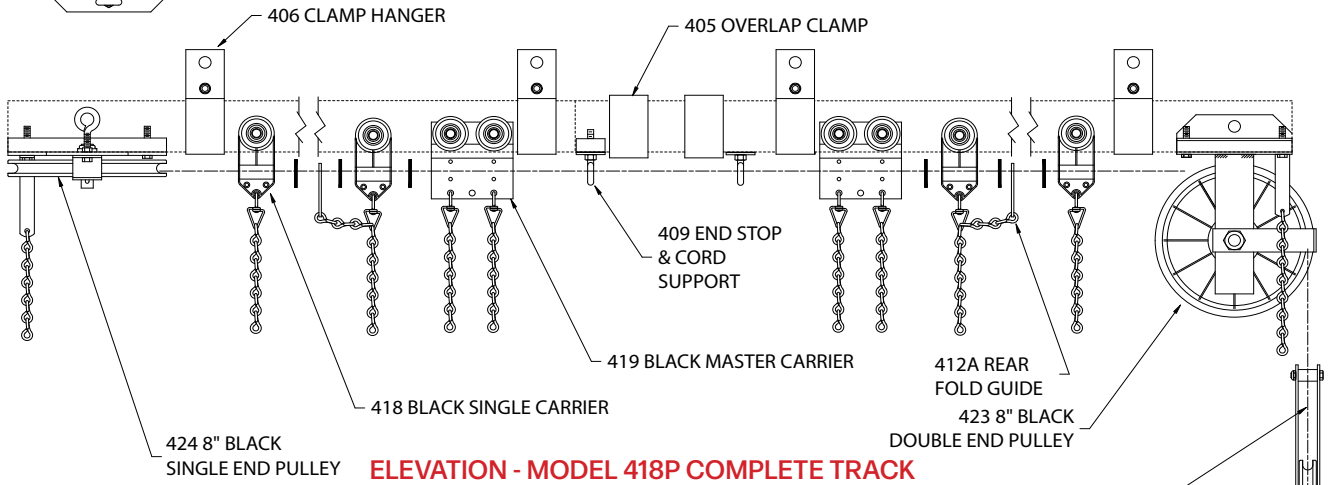
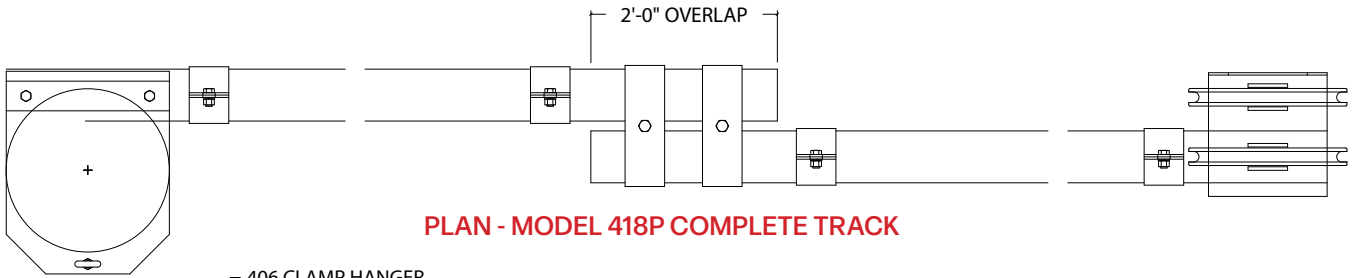

NOTE: 416P dimensions similar

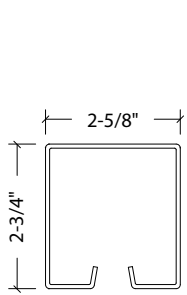

**410 TRACK**

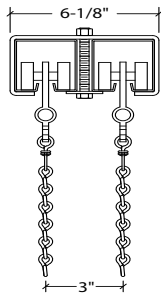

**TRACKS AT CENTER OVERLAP**

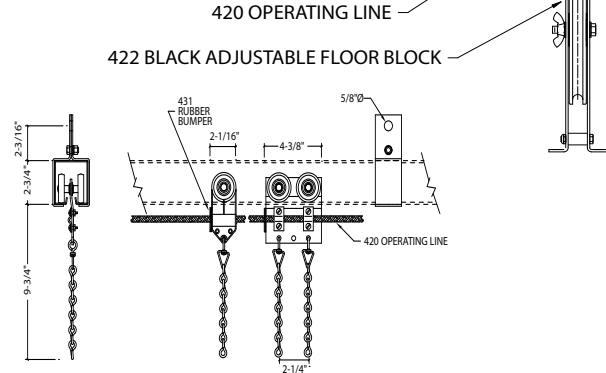

**418 SINGLE CARRIER AND 419 MASTER CARRIER**

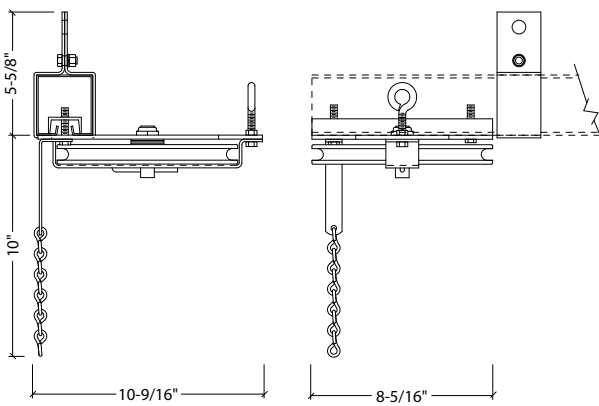

**424 8" BLACK SINGLE END PULLEY**

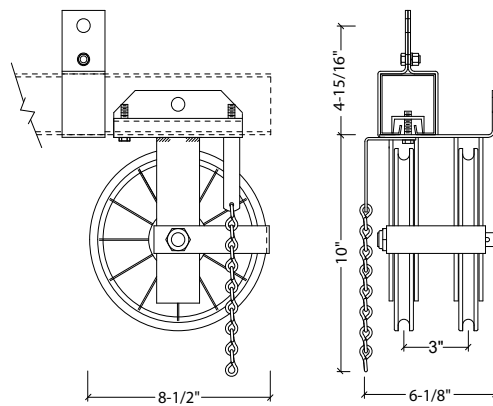

**423 8" BLACK DOUBLE END PULLEY**

# TRACK 428S SERIES

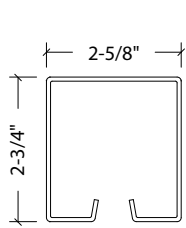
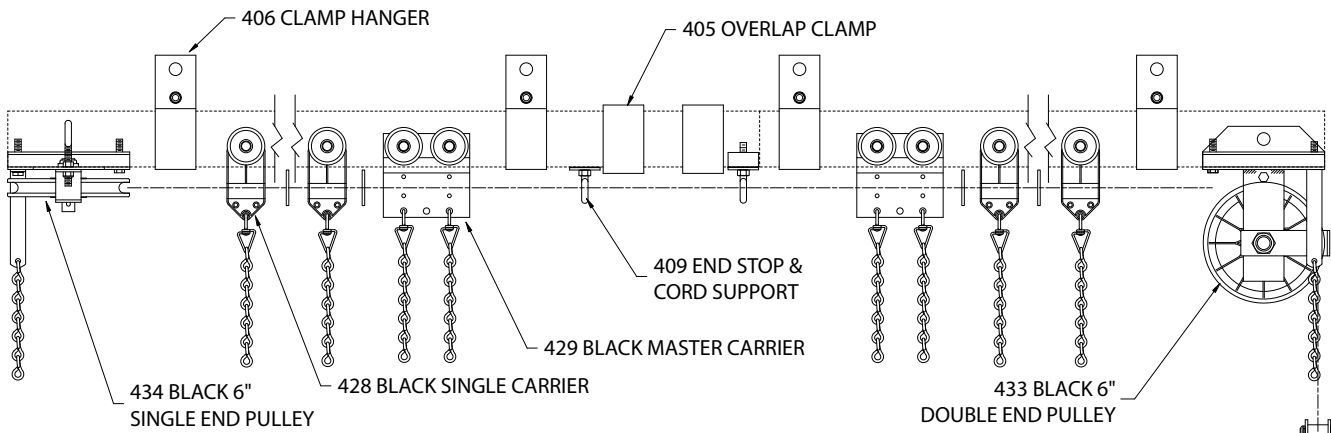
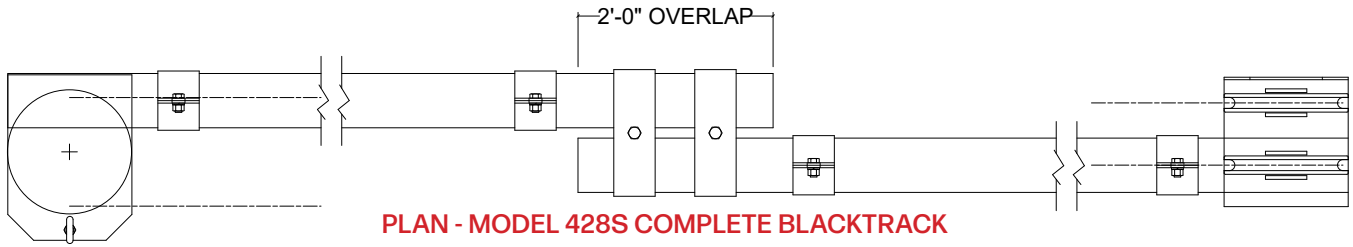

**410 TRACK**

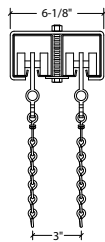

**TRACKS AT CENTER OVERLAP**

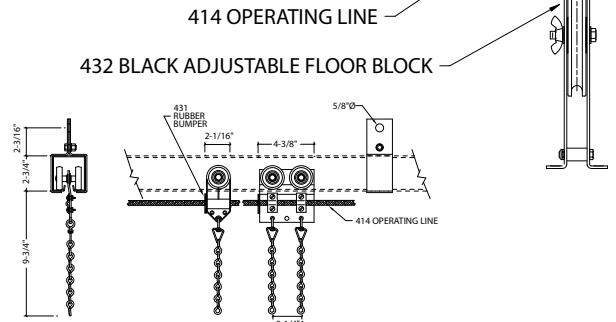

**428 BLACK SINGLE CARRIER AND 429 BLACK MASTER CARRIER**

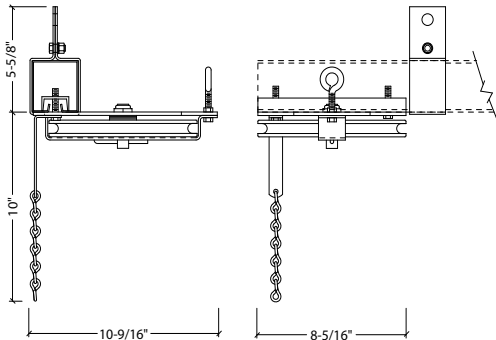

**434 6" BLACK SINGLE END PULLEY**

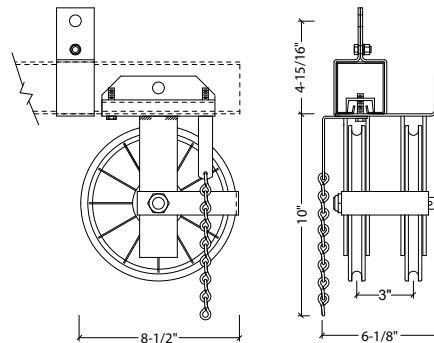

**433 6" BLACK DOUBLE END PULLEY**