

HEAVY DUTY STRAIGHT STUDIO TRACK MODEL NO. 1018S

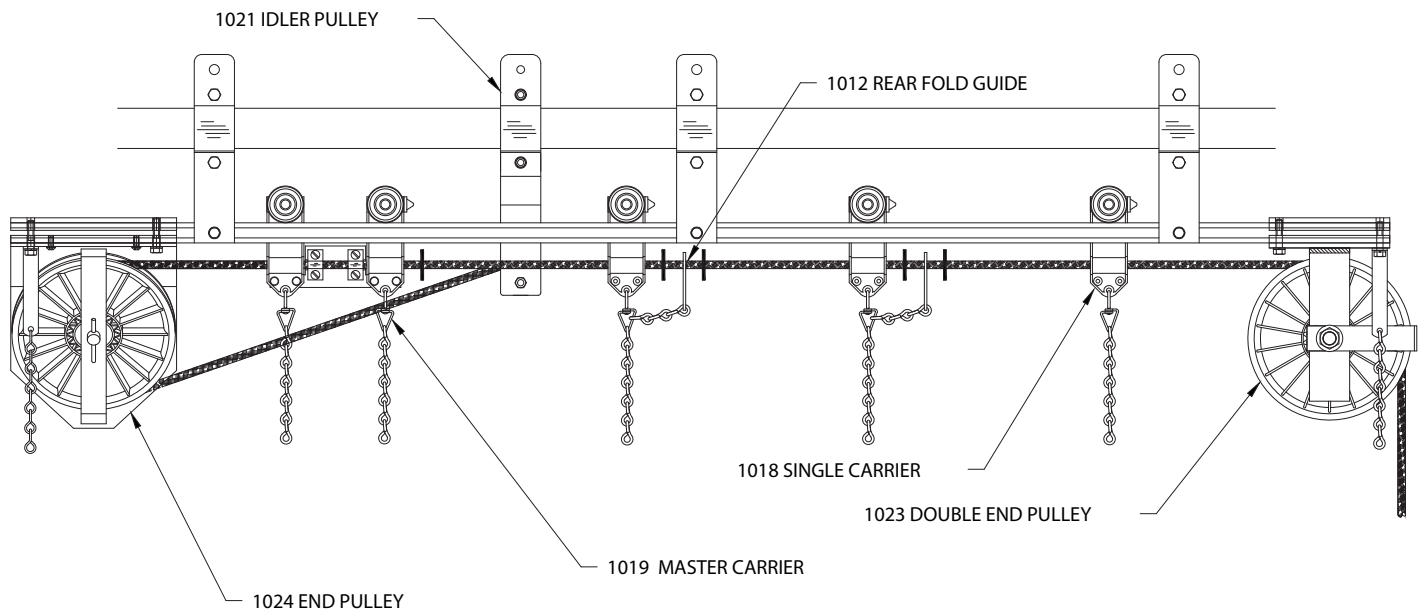

Model No. 1018S Heavy-Duty Straight Track was developed especially for use in television studios where an exceptionally quiet, heavy-duty open style track is desired. Equipped with urethane-tired shielded ball bearing wheels and neoprene bumpers to insure the quietest operation available in a stage track. Track furnished with rear fold guides which enable curtain to fold at offstage edges during operation. Track sections available in 10 and 20 foot standard lengths.



No. 1018 BLACK SINGLE CARRIER

2 urethane-tired shielded ball bearing wheels riveted to black MD Nylon body with heavy-duty hook, swivel and 6" trim chain for curtain attachment. Supplied with 1 No. 1031 rubber bumper.

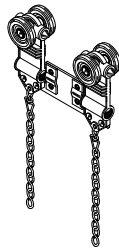

No. 1019 BLACK MASTER CARRIER

2 No. 1018 single carriers riveted to steel body. 2 clamps provided for anchoring line or cable. Supplied with 1 No. 1031 rubber bumper. 1 pair required for overlapping tracks.

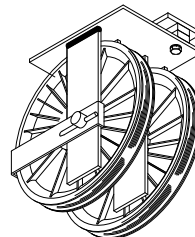

No. 1023 8" BLACK DOUBLE END PULLEY

8" diameter MD Nylon sheaves with precision sealed ball bearings. Heavy-duty steel housing clamps to underside of track. Chain bracket for securing offstage curtain edge. Grooved for 1/2" operating line.

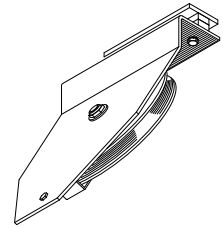

No. 1024 BLACK 8" SLANTED SINGLE END PULLEY

8" diameter MD Nylon sheave with sealed precision ball bearings. Heavy-duty steel housing clamps to underside of track. Chain bracket for securing offstage curtain edge. Grooved for 1/2" operating line.

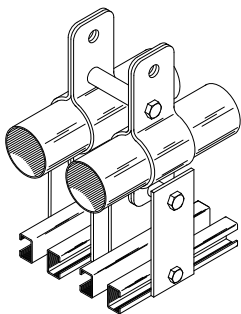

No. 1005 BLACK OVERLAP CLAMP

Tubing spacers mounted between batten clamps to rigidly hold tracks in position at overlap. 1 set required.

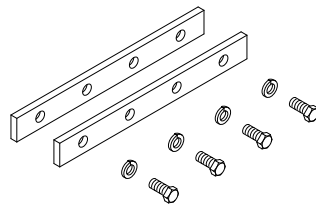

No. 1007 BLACK BAR SPLICE

Steel brackets for aligning "C" channels. With all necessary hardware.

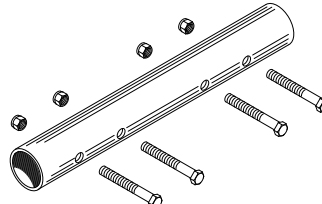

No. 1007P BLACK BATTEN SPLICE

Steel tube splice for backbone. With all necessary hardware.

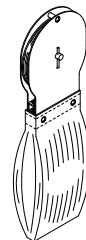

No. 1043 SAND BAG TENSION PULLEY

8" MD Nylon sheave with precision ball bearings in specially designed housing with heavy-duty sand bag. For maintaining proper operating line tension on flying curtains. Supplied without sand. Grooved for 1/2" operating line.

HEAVY DUTY STRAIGHT STUDIO TRACK MODEL NO. 1018S

GENERAL SPECIFICATIONS

Provide **Model 1018S** as manufactured by H & H Specialties Inc., South El Monte, CA.

Track shall be constructed of carrier rails roll-formed from 16 gauge galvanized steel into 1" x 5/8" "C" channel. Track rails shall be finished with a semi-gloss black powder coat. Two rails shall be suspended from 1-1/2" Sch. 40 pipe backbone on 2'-0" intervals by steel hanger assemblies creating a 3/4" continuous slot for passage of carrier bodies.

Provide single carriers, spaced on 12" centers, constructed of two urethane-tired shielded ball bearing wheels fastened parallel to MD Nylon carrier body with integral glides to keep carrier aligned at all times. Install tapered neoprene bumper into carrier body to reduce noise. Supply with heavy-duty hook, swivel eye, and trim chain for attachment of curtain. Install rear fold guide and two round neoprene bumpers between each carrier to fold curtain at offstage edges and minimize noise.

Master carriers shall consist of two single carriers riveted to formed steel master plate. Connect to operating line with two formed steel cord clamps.

Single and double end pulleys shall bolt securely to the track rails and shall be equipped with 8" diameter MD Nylon sheaves grooved for 1/2" operating line. Install two 5/8" sealed precision ball bearings in each sheave.

Provide 8" MD Nylon sheave with precision ball bearings in specially designed housing with heavy-duty sand bag to maintain proper operating line tension.

Black operating line shall be 1/2" diameter, stretch-resistant rope with spun polyester outer jacket braided over polyester core. Install idler pulleys on each side of track to support operating line.

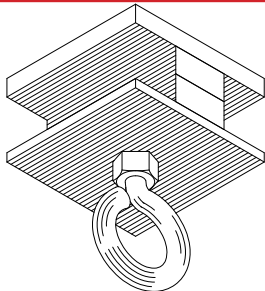

No. 1009 BLACK

END STOP & CORD SUPPORT

Steel clamp with eye to support operating line and prevent carriers from traveling beyond desired location. 1 pair required for overlapping tracks.

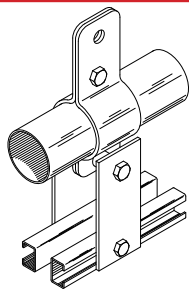

No. 1010 BLACK TRACK

Track is assembled to customer's requirements. Cord operated use only. Track available in 10' and 20' standard lengths.

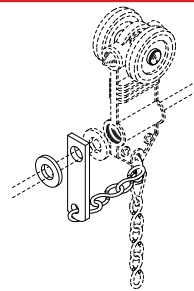

BLACK REAR FOLD GUIDE

Allows curtain to fold at offstage edges. Supplied with 1 No. 1031 rubber bumper. **No. 1012** - for 1/2" hand line.

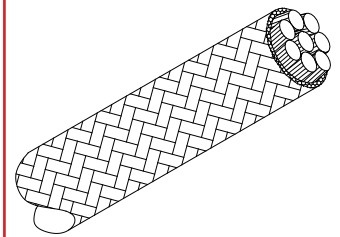

No. 1020 OPERATING LINE

1/2" diameter black spun polyester braided over polyester core for manual operation.

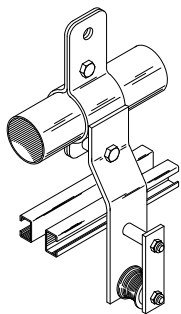

No. 1021 BLACK IDLER PULLEY

MD Nylon roller with 5/16" shielded ball bearings mounted to steel bracket. Provides support for operating line.

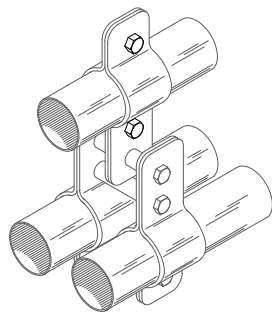

No. 1026 BLACK

CENTER PIPE SUPPORT

Formed steel assembly to align track at overlap.

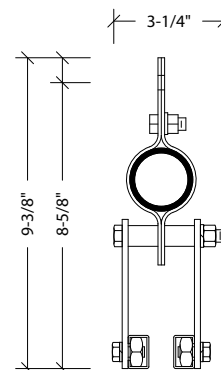

No. 1010 BLACK TRACK

1018S TRACK

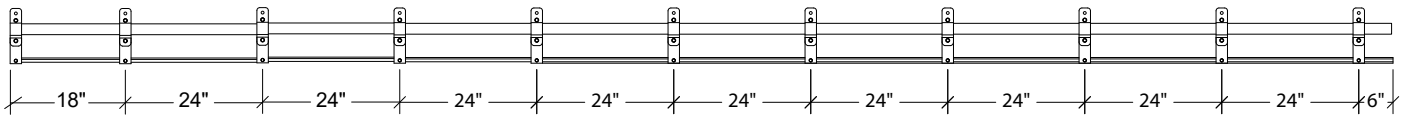
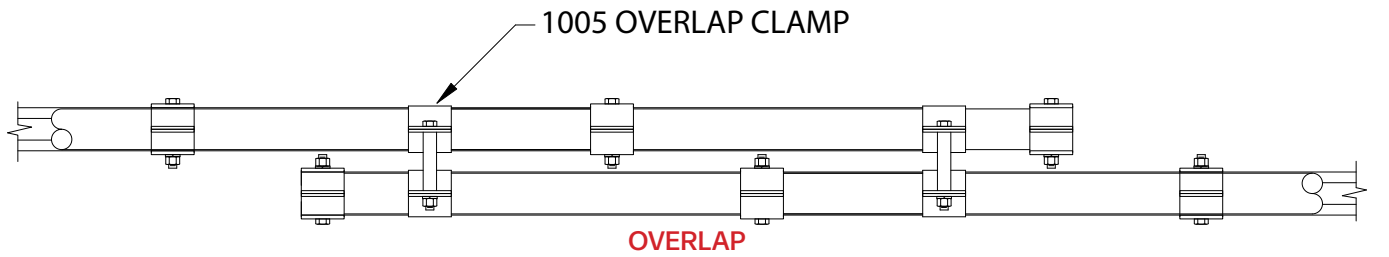

TRACK ASSEMBLY - TYP.

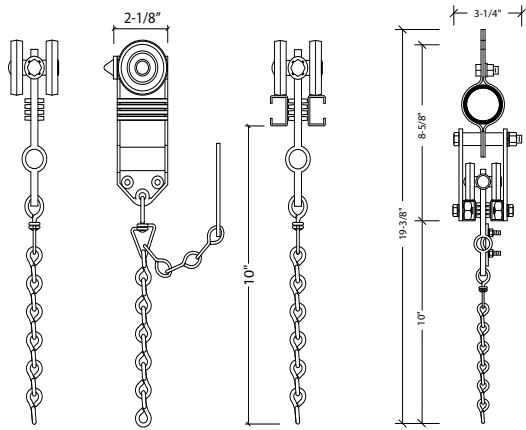
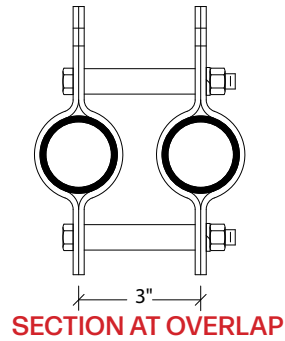
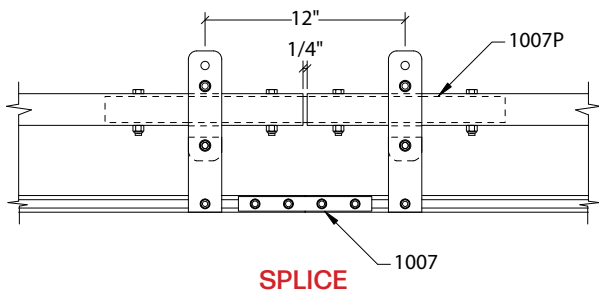

1018 SINGLE CARRIER

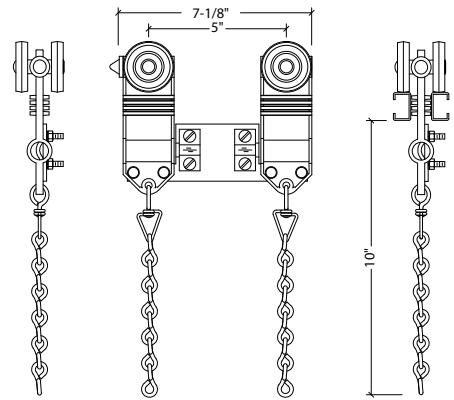

1019 MASTER CARRIER

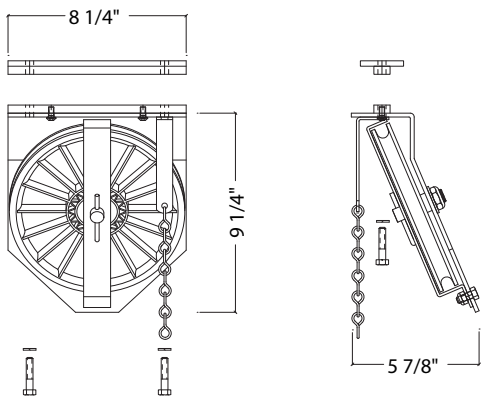

1024 SINGLE END PULLY

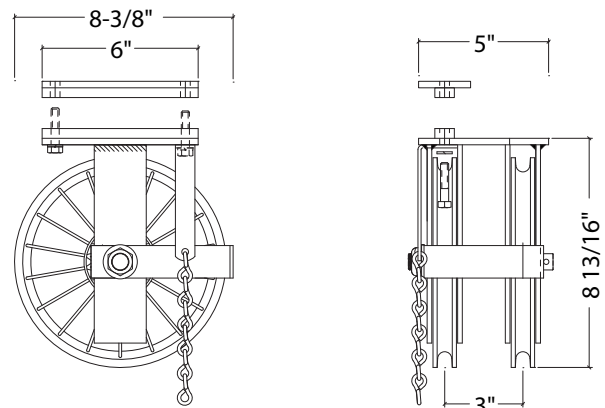

1023 DOUBLE END PULLY