

Series 40 UPRIGHT LOFT BLOCKS

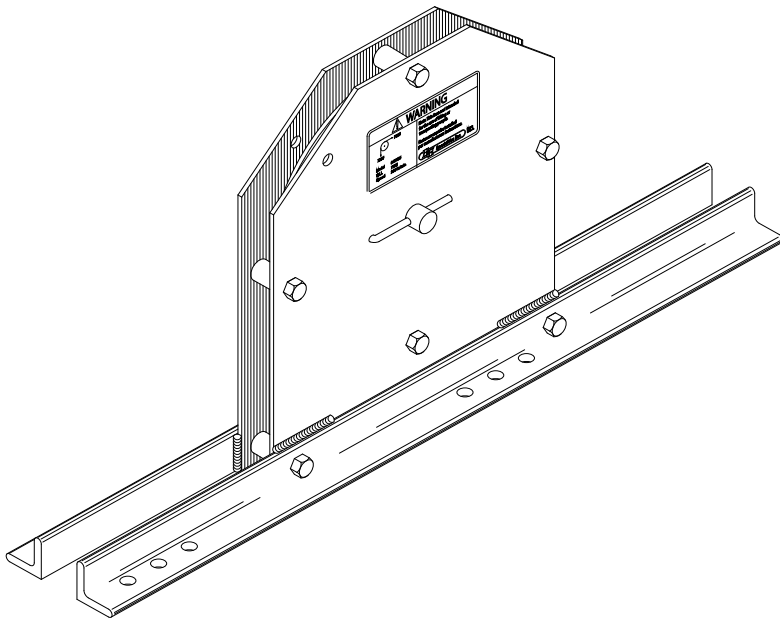

Series 40 loft blocks are designed to mount on top of grid or other support structure. Each rigid steel housing contains a single-groove sheave rotating on sealed precision ball bearings.

Each base angle is punched with a series of holes to accommodate a wide variety of loft well configurations. Mounting clips and bolts are supplied for attachment to the support structure.

Model Number	Sheave Diameter	Sheave Material	Cable	Bearing	WLL *
640N19	6"	Nylatron GS	3/16"	5/8" BB	400#
640N50	6"	Nylatron GS	1/2"	5/8" BB	250#
840C25	8"	Cast Iron	1/4"	5/8" BB	450#
840C75	8"	Cast Iron	3/4"	5/8" BB	400#
840N19	8"	Nylatron GS	3/16"	5/8" BB	525#
840N25	8"	Nylatron GS	1/4"	5/8" BB	725#
1040C25	10"	Cast Iron	1/4"	5/8" BB	550#
1040C31	10"	Cast Iron	5/16"	5/8" BB	690#
1040C75	10"	Cast Iron	3/4"	5/8" BB	500#
1040N25	10"	Nylatron GSM	1/4"	1" BB	875#
1040N31	10"	Nylatron GSM	5/16"	1" BB	1150#
1240C25	12"	Cast Iron	1/4"	1" BB	700#
1240C38	12"	Cast Iron	3/8"	1" BB	1025#
1240N25	12"	Nylatron GSM	1/4"	1" BB	875#
1240N38	12"	Nylatron GSM	3/8"	1" BB	1500#

BB - Sealed precision ball bearings. Tapered roller bearings available.

* Weight in pounds @ 300 ft/min.

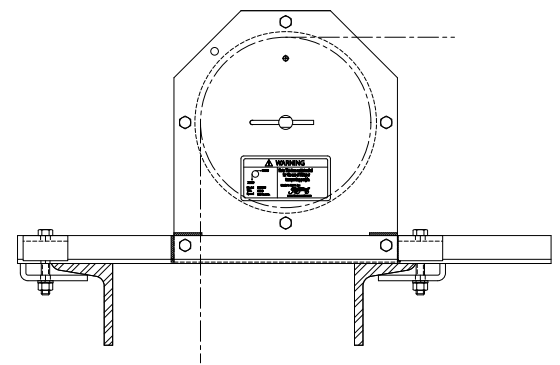

Typical Mounting Application