

## Series 30 UNDERHUNG LOFT BLOCK

Series 30 loft blocks are designed to clamp to the bottom of steel wide flange beams. A single-groove sheave rotates on sealed ball bearings and is fully enclosed in a housing of heavy steel side plates welded to base angles.

Each Series 30 loft block is fabricated to fit a specific beam size. Mounting holes are located such that the lift line is positioned at the center of the beam. Offset clips and bolts are supplied for attachment to the support structure. Beam flange width and thickness must be specified at the time of ordering.

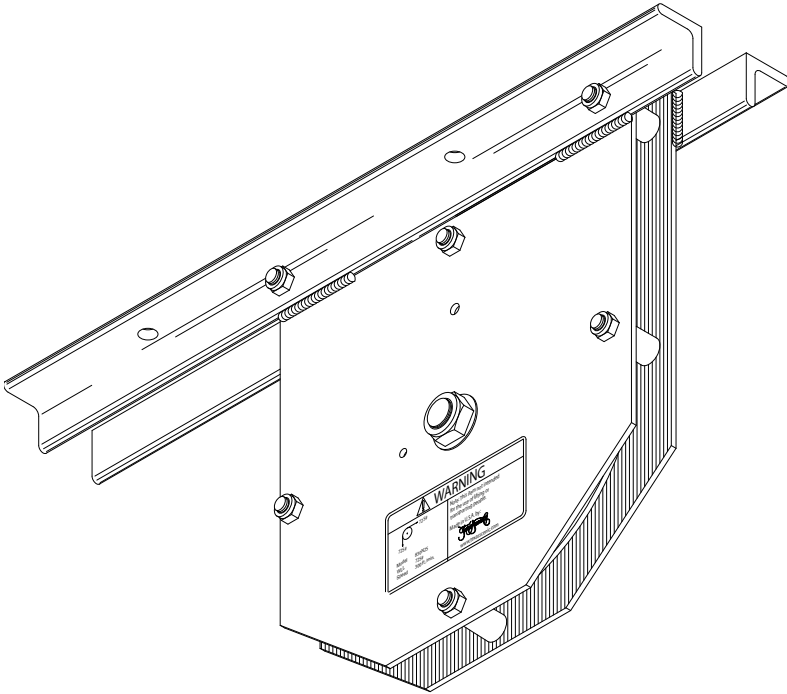

Model Number	Sheave Diameter	Sheave Material	Cable	Bearing	WLL *
630N19	6"	Nylon	3/16"	5/8" BB	400#
630N50	6"	Nylon	1/2"	5/8" BB	250#
830C25	8"	Cast Iron	1/4"	5/8" BB	450#
830C75	8"	Cast Iron	3/4"	5/8" BB	400#
830N19	8"	Nylon	3/16"	5/8" BB	525#
830N25	8"	Nylon	1/4"	5/8" BB	725#
1030C25	10"	Cast Iron	1/4"	5/8" BB	550#
1030C31	10"	Cast Iron	5/16"	5/8" BB	690#
1030C75	10"	Cast Iron	3/4"	5/8" BB	500#
1030N25	10"	Nylon	1/4"	1" BB	875#
1030N31	10"	Nylon	5/16"	1" BB	1150#
1230C25	12"	Cast Iron	1/4"	1" BB	700#
1230C38	12"	Cast Iron	3/8"	1" BB	1025#
1230N25	12"	Nylon	1/4"	1" BB	875#
1230N38	12"	Nylon	3/8"	1" BB	1500#

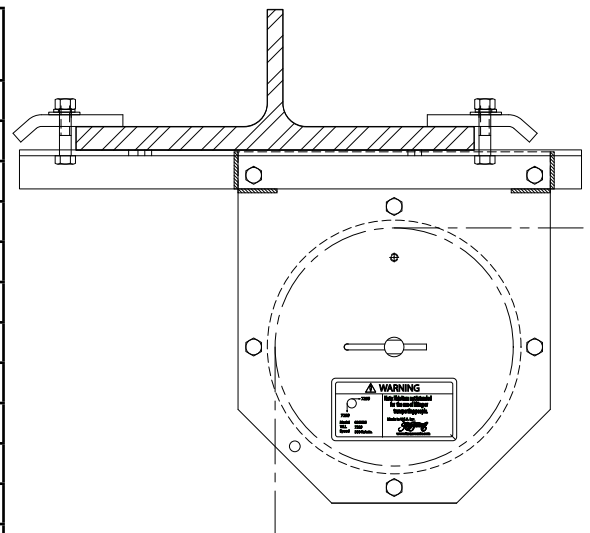

Typical Mounting Application

BB - Sealed precision ball bearings. Tapered roller bearings available.

\* Weight in pounds @ 300 ft/min.