

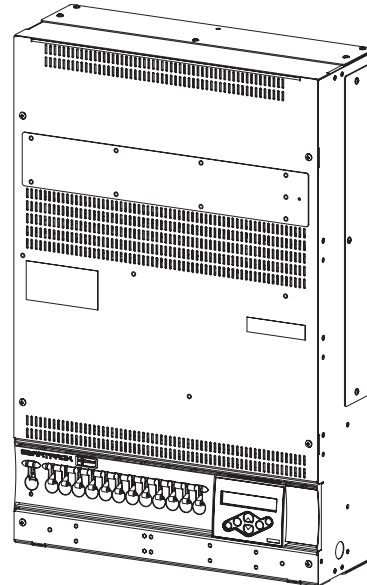

115/120V

Smart Solutions™ Series

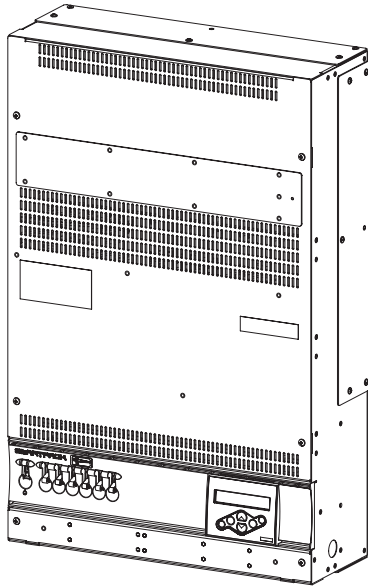

GENERAL INFORMATION

The extreme functionality of the SmartPack built into a compact affordable wall mount unit. This small wall mount pack provides easy operation and reliability as well as quiet performance. SmartPack Wall Mount comes standard with SmartLink® control. When used with the optional LinkPower Supply, the system allows up to four SmartLink Stations to be connected for remote operation of presets and sequences.

APPLICATIONS

- Ballrooms
- Restaurants
- Churches
- Multi-purpose rooms
- Small corporate meeting rooms
- Small performance spaces

FEATURES

- 6 or 12 dimmer units available
- Capable of dimming multiple load types: incandescent, low voltage, 2-wire fluorescents
- Versatile control via DMX-512 and/or SmartLink
- DMX addressing and softpatch via keypad
- Built-in presets (32) and sequencer with programmable fade and hold times allows stand-alone operation
- SmartLink provides synchronization of presets and sequence across multiple packs
- Optional LinkPower Supply powers four stations
- Auto-Restart function returns unit to previous state when power is cycled
- Control-power switch puts unit in stand-by mode
- Multi-language capability – English, Spanish, German and French
- Fully rated magnetic circuit breakers
- Bypass contact input instantly switches selected loads on, while switching others off
- Full compliance with UL, cUL, FCC and CE regulations

ORDERING INFORMATION

SmartPack Wall Mount

MODEL	DESCRIPTION
SL620W	6 x 20A SmartPack Wall Mount
SL620W-LPS	6 x 20A SmartPack Wall Mount with LinkPower Supply
SL1210W	12 x 10A SmartPack Wall Mount
SL1210W-LPS	12 x 10A SmartPack Wall Mount with LinkPower Supply

SmartPack Wall Mount Accessories

MODEL	DESCRIPTION
SMPK-RRM	Rack Mount Kit (rails)

SmartLink Accessories

MODEL	DESCRIPTION
S-LPS	LinkPower Supply Kit
S-10005	SmartLink 5-Button Station*
S-10010	SmartLink 10-Button Station*
S-ATC	SmartLink Astronomical TimeClock

*Stations require one LinkPower Supply per system. Only one LinkPower Supply allowed per system. Four stations supported.



SPECIFICATIONS

GENERAL

- Approvals and Certifications:
 - Underwriters Laboratories tested and Listed to the following standards:
 - UL508 (File: E152039)
 - Complies with ESTA DMX512-A Standards

ELECTRICAL

- Maximum feed capacity:
 - 3 x 40A, Three Phase, 4-wire & ground
 - 2 x 60A, Single Phase, 3-wire & ground
- Easily switches from single phase to three phase
- Input voltage Range from 85 – 140VAC, 47 – 63 Hz
- Input lugs rated for up to 2AWG
- Standard output connection via DIN Rail spring terminals, rated for up to 8AWG
- Fully rated magnetic circuit breakers to eliminate nuisance tripping
- High quality 200µs toroidal filters
- Modular SCR and bonded heat sink assembly with superior surge, thermal transfer, and short-circuit immunity
- 2500V isolation between control and power components

CONTROL WIRING

- Removable terminals for DMX512, SmartLink and Contact Input rated for maximum of 12AWG wire

MECHANICAL

- 16-gauge steel construction
- Fine-textured, scratch resistant paint
- Removable knockout panels with pass-through plenum for side-by-side or top-to-bottom mounting configurations (sides, top and bottom)
- Full front access (side clearance not required)
- Optional rack mount kit (requires 15U spacing)
- Recessed control connectors and protected circuit breakers

THERMAL

- Ambient operation temperature between 32°F (0°C) and 95°F (35°C)
- Humidity between 30 – 95% (non-condensing)
- Fan-forced airflow from bottom to top
- Low noise temperature controlled fan
- Efficiency = 96% or better, maximum dissipation 3% of connected load (Max. 3,100 BTUs)

USER INTERFACE

- High-contrast 20-character by 2-line backlit LCD
- 6-button blue phosphorescent keypad
- Power status indicator LED (Blue)
- DMX status indicator LED (Green)

PHYSICAL

SmartPack Wall Mount Dimensions

MODEL	HEIGHT		WIDTH		DEPTH	
	inches	mm	inches	mm	inches	mm
SL620W	26.24	666	17.14	435	6.2	157
SL1210W	26.24	666	17.14	435	6.2	157

SmartPack Wall Mount Weight

MODEL	WEIGHT	
	lbs	kgs
SL620W	46.2	20.96
SL1210W	48.0	21.77

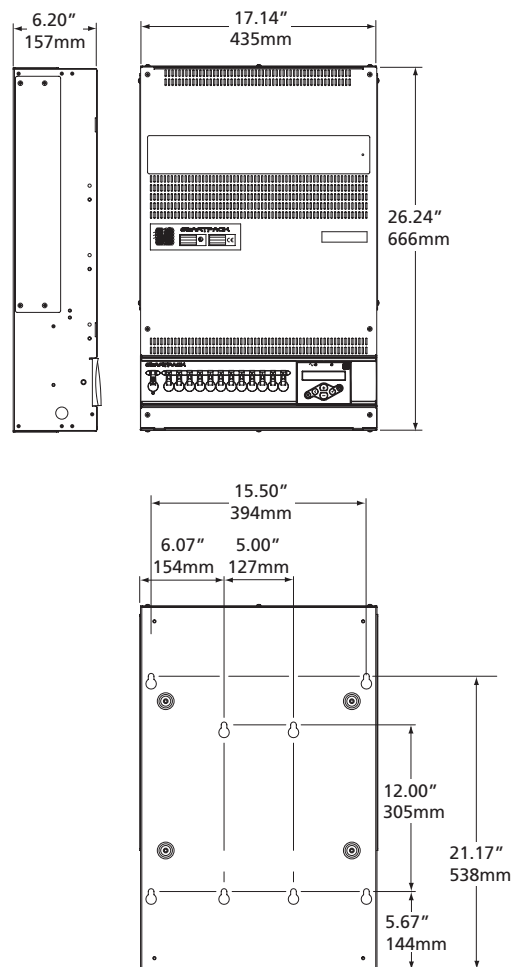

Corporate Headquarters • 3031 Pleasant View Rd, PO Box 620979, Middleton WI 53562 0979 USA • Tel +1 608 831 4116 • Fax +1 608 836 1736
London, UK • Unit 26-28, Victoria Industrial Estate, Victoria Road, London W3 6UU, UK • Tel +44 (0)20 8896 1000 • Fax +44 (0)20 8896 2000
Rome, IT • Via Ennio Quirino Visconti, 11, 00193 Rome, Italy • Tel +39 (06) 32 111 683 • Fax +44 (0) 20 8752 8486
Holzkirchen, DE • Ohmstrasse 3, 83607 Holzkirchen, Germany • Tel +49 (80 24) 47 00-0 • Fax +49 (80 24) 47 00-3 00
Hong Kong • Room 1801, 18/F, Tower 1 Phase 1, Enterprise Square, 9 Sheung Yuet Road, Kowloon Bay, Kowloon, Hong Kong • Tel +852 2799 1220 • Fax +852 2799 9325
Web • www.etcconnect.com • Copyright©2008 ETC. All Rights Reserved. All product information and specifications subject to change. 7021L1000 Rev. D Printed in USA 05/08

SmartLink® products protected by US and International patents pending